

PRODUCT DATASHEET

ClearView[®] db

VIS-NIR Analyzer – Dual-Beam Photometer



Real-time

Configurable

Continuous PAT

- Color — ASTM or Saybolt color in fuels
- OH (hydroxyl) number for polymer reaction end point
- Water content in solvents
- Haze in diesel fuel with turbidity option
- NaOH in water

GUIDED WAVE'S ClearView db photometer is the first commercially available true dual-beam filter photometer. A primary attraction of any photometric analyzer is its low cost; however, the compromise is usually performance. Guided Wave has dramatically improved photometer performance by adding our unique dual-beam optics, which provides long term, stable operation. The flexible configurations of the ClearView db also meet many online analysis requirements for liquid and gas process streams.

ClearView db Benefits

- Stable dual-beam design decreases drift due to lamp aging – yielding long-term performance
- Several enclosure options means lowest installation costs
- Six filter positions make multi-parameter analysis a possibility
- Optional second sample channel for lower cost per sample point
- Optional turbidity monitoring
- Compatible with a wide range of flow cells and insertion probes
- Low maintenance
- Long life Tungsten-Halogen Lamp (>4000 hours typical)
- Dual-beam performance lengthens time between required probe cleanings

Principle of Operation

Photometry is fundamentally the measurement of the intensity of light. Observable on many levels, changes in light intensity occur as a result of interactions with different materials. Further, the Beer-Lambert Law describes a useful relationship between light and matter. Matter absorbs light in measurable amounts at specific wavelengths. The degree of absorption correlates to the concentration of matter that is exposed to the light across a known optical distance, or pathlength. Thus, chemical concentrations and physical characteristics of a process stream sample can be accurately analyzed. Effective analyzer design permits this principle to be taken online, powerfully exploiting the science and achieving a high level of process control. Each successful ClearView db application is defined by the calibration. The calibration consists of absorption data corresponding to analytical values that describe the state of the process stream. Wavelengths specified for the application are represented by filters installed in the photometer. If and when changes occur in the process, the ClearView db measurements reflect this instantaneously.

Complete Analyzer System

The ClearView db is a complete analytical system comprised of three main components: 1) the photometer, 2) the fiber optic cables, and 3) the sample interface. The photometer both transmits the source light and quantifies the light that was not absorbed by the sample. Optical grade fiber cables are used to carry the light from the photometer to the sample and back. Using high performance fiber cables permits the sample interface to be located up to 100 meters from the photometer. Often the success of an analyzer hinges on the proper selection of the sample interface. The ClearView db is compatible with the large selection of Guided Wave rugged and efficient sample interfaces. Now photometry is an option in even the harshest environments.

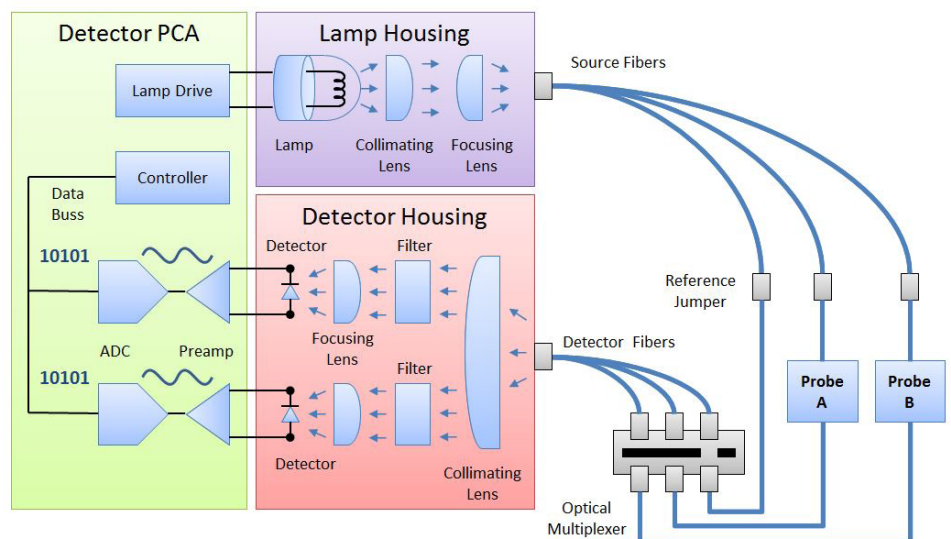

Specifications:	
Design:	Fiber Optic Dual-Beam Photometer
No. of Channels:	2 Sample Channels, optional Turbidity Monitoring for 1st Channel only
Number of Detectors/Filters:	2 – 6, any combination of detector types except 3 xInGaAs max
Filters:	As per customer requirements, max 6 individual filters
Detector Types:	Si (450 nm – 1050 nm) InGaAs (800 – 1650 nm) xInGaAs (1000 – 2150 nm, TE cooled), max 3
Light Source:	Tungsten-Halogen, >4000 hours typical
Spectral Range:	450 nm to 2150 nm
Photometric Noise:	<50 μ AU 450-2100 nm 1 minute rms
Photometric Drift:	<500 μ AU rms/ °C
Wavelength Drift:	Property of Filter
Response Time:	1 second, minimum. User settable
Fiber Size:	400, 500, or 600 μ m diameter, single strand
Fiber Type Fused Silica:	Ultra Low-OH (optimum range: 450 nm – 2150 nm)
Fiber Connectors:	SMA 905
Outputs (analog):	Up to 4 per Channel for a 2 Channel Unit 4 – 20 mA, customer powered
Outputs (discreet):	Up to 4 per Channel for a 2 Channel Unit Contact closures
Inputs (analog):	4 (optional) 4 – 20 mA, isolated grounds
Local Display:	LCD Touch Screen, color QVGA
Communications:	Ethernet (TCP Modbus) standard
Enclosures:	General Purpose NEMA 4 Class I Division 2, Z-Purge, NEMA 4x Class I Division 1, IECEx, ATEX
Power:	24 VDC, 3 A
Environmental:	0 – 45°C, 0 – 90%, sun and rain sheltered
Dimensions: (H x W x D)	GP – 14"x 12"x 6" [36 cm x 31 cm x 15 cm] CID2 – 16"x 20"x 6" [41 cm x 51 cm x 15 cm] Explosion proof – 16"x 17"x 10" [41 cm x 43 cm x 26 cm]

PREMIUM INSIGHTS – GAIN REAL-TIME INSIGHT INTO YOUR PROCESS

Process Insights' products and solutions deliver innovative and differentiated analysis and measurement solutions and technologies that add high value to our customers and protect the environment.

Our commitment is to deliver smart and affordable innovation that optimizes process, improves safety, and transforms our world.

CENTERS OF EXCELLENCE

PROVIDING PROVEN SOLUTIONS FROM A GLOBAL TECHNOLOGY LEADER

Guided Wave

3033 Gold Canal Drive
Rancho Cordova, CA 95670
USA
+1.916.638.4944
www.guided-wave.com
gwsales@guided-wave.com
gwsupport@guided-wave.com

Process Insights – The Americas

4140 World Houston Parkway
Suite 180
Houston, TX 77032
USA
+1 713 947 9591
info@process-insights.com

Process Insights – EMEA

ATRICOM
Lyoner Strasse 15
60528 Frankfurt
Germany
+49 69 20436910
info@process-insights.com

Process Insights – APAC

Wujiang Economic and Technology
Development Zone
No. 258 Yi He Road, 215200 Suzhou
Jiangsu Province China
+86 400 086 0106
info@process-insights.com

OUR PREMIUM GLOBAL BRANDS

