

PRODUCT DATASHEET

Fiber Optic Cable

Compatible with NIR and UV-VIS Analyzers

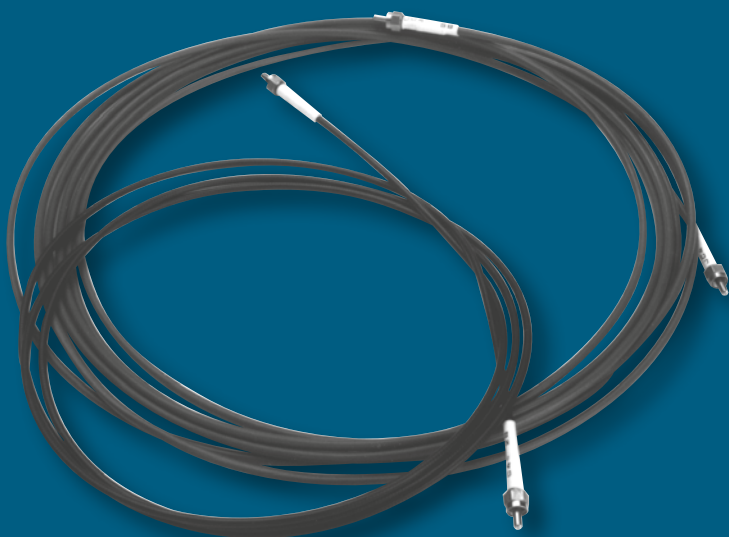

More signal

Less noise

Better measurement

- Designed specifically for process spectroscopy
- Intrinsically safe
- Brings the light to the sample

Fiber Optic Cable Brings the Light to the Sample

Signal stability and low noise in remote spectroscopy depend upon fiber optics with high transmission. The transmission must be affected very little by environmental influences such as temperature, vibration, and ambient light levels. From a patented fiber design to our emphasis on high-quality materials, Guided Wave spectroscopic grade optic cable is designed for the highest performance in transmission efficiency and durability. A polyimide coating and a patented silicone-based buffer protect the fiber. Some fiber optic cables also receive a tough outer jacket made of Tefzel™ and inner Kevlar™ strands for strength.

Manufacturing High Performance NIR Process Fiber

All Guided Wave optical fiber is constructed as a core-and cladding composite. The core – the filament that guides the light – consists of a thin strand of high-transmissivity fused silica. The cladding is an outer layer of doped, lower refractive index fused silica. This two-layer design keeps the light tightly confined to the central core of the fiber thus delivering a maximum amount of light at the far end. The diameter is tightly controlled during the drawing process. This produces a fiber that centers extremely well in connectors and has a very low loss rate per kilometer.

Unprotected silica fiber is quite fragile. To improve the NIR fiber's strength and flexibility, it is coated with a polyimide material during the drawing process. Then, another protective layer is added, a carbon-loaded buffer of silicone RTV (U.S. Patent #5,381,505). The buffer reduces stray light, both external ambient light that "leaks" through the jacket and internal stray light or "cladding" modes. Finally, Guided Wave adds an outer protective jacket. Our "process NIR fiber" – fiber optic cable for harsh environment applications or applications requiring long cable runs – receives a multi-layer jacket made of Tefzel™ and Kevlar™. The "laboratory fiber" – intended for short laboratory-bench runs – can be supplied in PVC-coated steel monocoil jacket, steel armored BX jacket, or PVC-zip tubing.

Two Kinds of Fiber Cable

Guided Wave offers two different kinds of optical fiber optimized for your spectral region of interest. Each type can be jacketed as outlined above and terminated in SMA, or FC style connectors. Cables and bare fiber are available in a variety of core diameters from 200 μm to 600 μm (contact Guided Wave for alternatives). The type of cable chosen depends on the application:

- Ultra Low-OH fiber provides the lowest possible amount of internal light attenuation. It is appropriate for visible or near infrared (VIS-NIR) spectroscopy. It is especially effective for applications that require increased sensitivity in the spectral region near 1385 nm or where very long cables are necessary (> 150 m). This cable is effective over the spectral range from 400 nm to 2100 nm.
- Deep UV (UV-SR) fiber is intended for spectroscopy in the ultraviolet and visible (UV/Vis) regions – 190 nm to 800 nm. Typically, to avoid high attenuation, cable length is kept short, < 50 m. SR stands for solarization resistant. Fiber that is exposed to UV light forms f-centers which reduce the transmission of the fiber.

Guided Wave Process Jacketed Fiber Optic Cable Anatomy

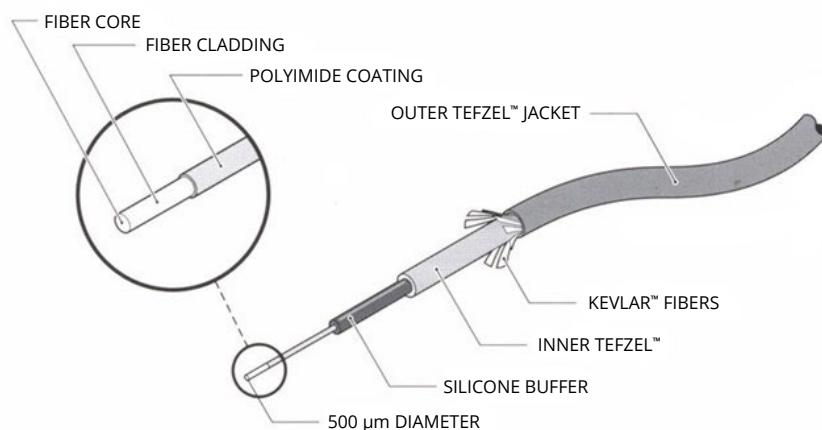

Specifications:	Ultra Low-OH Fiber	Deep UV Fiber (UV-SR)
Spectral (Wavelength) Range	400-2100 nm	190-850 nm
Typical Application	VIS -NIR	UV-VIS
Typical Fiber Run (Length)	10 to 250 m	< 50 m
Maximum Temperature (Bare or Armored)	315 °C*	315 °C*
Maximum Temperature (Tefzel Jacket)	165 °C*	165 °C*
Maximum Temperature (PVC)	105 °C*	105 °C*
Minimum Temperature	-20 °C**	-20 °C**
Numerical Aperture (NA)	0.22 ± 0.02	0.22 ± 0.02
Baseline Attenuation (Unjacketed)	≤ 3 dB/km @ 1550 nm	< 1 dB/m @ 200 nm
Attenuation Difference (1385 nm - 1550 nm)	< 5 dB/km	NA

* If High-Temp Epoxy is used for termination. ** Contact Guided Wave for alternatives.

Performance Characteristics of GW Fiber

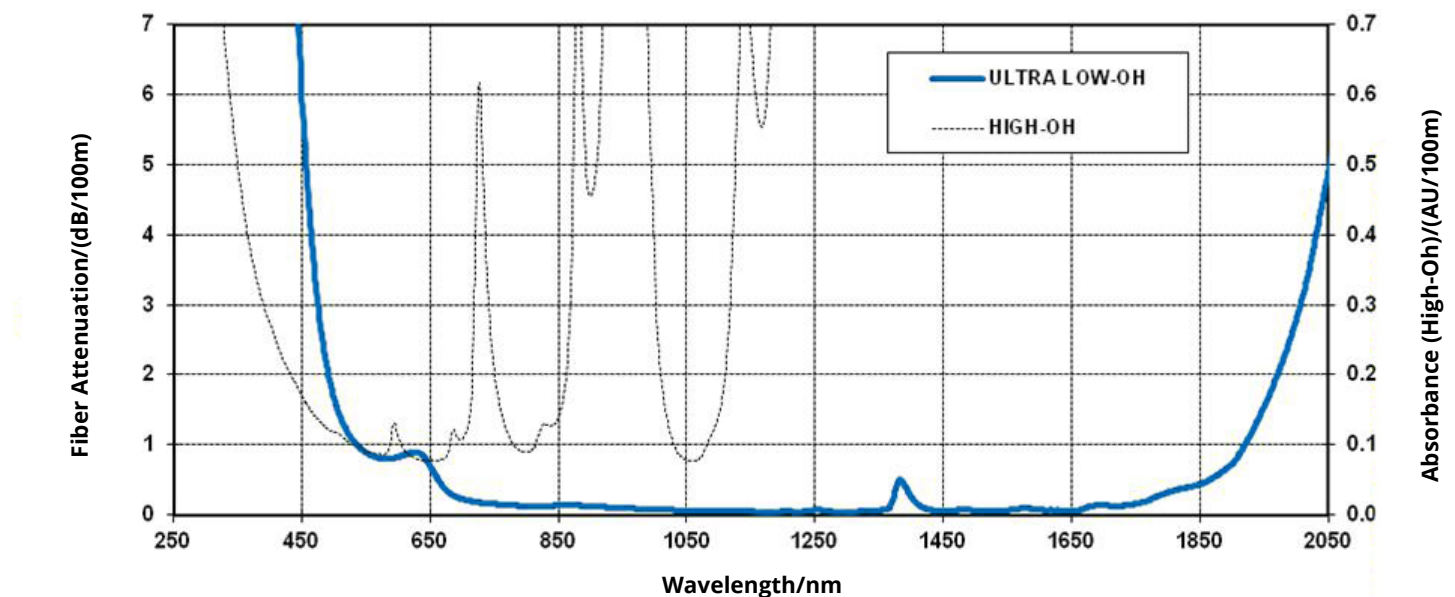

Fiber Jacketing Options

- Process fiber cable: Tefzel™-Kevlar™
- Laboratory fiber cable: PVC-coated, steel monocoil jacket
- Armored fiber cable: Steel BX Armor with PVC Jacket (150 meter max length)**

Fiber Termination Options

- SMA 905
- FC
- Custom (call Guided Wave)
- Bifurcated (call Guided Wave)
- Unterminated

Available Diameters – Core/Cladding/Polyimide

- 200/220/239 μm (15 meter maximum length)
- 400/440/480 μm
- 500/550/590 μm
- 600/660/710 μm

Optional Accessories

- SMA 905 and FC Bulkhead Unions
- SMA 905 to FC Adapter
- Fiber Termination Kit and accessories
- Calibrated torque wrench for SMA 905 connectors

PREMIUM INSIGHTS – GAIN REAL-TIME INSIGHT INTO YOUR PROCESS

Process Insights' products and solutions deliver innovative and differentiated analysis and measurement solutions and technologies that add high value to our customers and protect the environment.

Our commitment is to deliver smart and affordable innovation that optimizes process, improves safety, and transforms our world.

CENTERS OF EXCELLENCE

PROVIDING PROVEN SOLUTIONS FROM A GLOBAL TECHNOLOGY LEADER

Guided Wave

3033 Gold Canal Drive
Rancho Cordova, CA 95670
USA
+1.916.638.4944
www.guided-wave.com
gwsales@guided-wave.com
gwsupport@guided-wave.com

Process Insights – The Americas

4140 World Houston Parkway
Suite 180
Houston, TX 77032
USA
+1 713 947 9591
info@process-insights.com

Process Insights – EMEA

ATRICOM
Lyoner Strasse 15
60528 Frankfurt
Germany
+49 69 20436910
info@process-insights.com

Process Insights – APAC

Wujiang Economic and Technology
Development Zone
No. 258 Yi He Road, 215200 Suzhou
Jiangsu Province China
+86 400 086 0106
info@process-insights.com

OUR PREMIUM GLOBAL BRANDS

